



Geotextile Sand Filter

Virginia

Installation Manual for TL-2 Collection and Sampling

July 2010



Distributed By:

**125 McKee Street
East Hartford, CT 06108
Tel: 800-444-1359 • Fax: 860-610-0427
www.eljen.com**

Introduction

The purpose of this manual is to help provide an easy and effective way to monitor and sample Eljen Alternative Onsite Sewage Systems per Section 12VAC5-613-80 of *Chapter 613 - Emergency Regulations for Alternative Onsite Sewage Systems*. Installing an Eljen Sampling and Collection Unit will allow you to sample your TL-2 Alternative Onsite Sewage Systems and meet the requirements listed below. If you have any questions pertaining to any part of this document or regarding Eljen products in general, please call our Technical Services Department at 1-800-444-1359.

OWNER RESPONSIBILITIES: The following requirements are in accordance with the *Virginia Emergency Regulations for Alternative Onsite Sewage Systems*.

- Maintain an operator: At all times, a certified service provider should be retained for routine maintenance and inspections for all TL-2 systems.
- Keep a log: A log must be maintained on any services or inspections conducted on the TL-2 system by the owner and operator. Requirements for log entries are in the section below, *Operators Responsibilities*.
- Keep operators manual on the premises and for transfer to next owner.
- Schedule routine Operator visits.
 - All TL-2 systems require a check 180 days after its initial operation. A grab sample is required to be tested by an EPA certified laboratory and results reported to the Local Health Department.
 - After approval, the system requires inspection once a year by an Operator.
 - Every five years, a grab sample is required to be tested by EPA certified laboratory and results reported to the Local Health Department.

OPERATOR RESPONSIBILITIES: The following requirements are in accordance with *Virginia Emergency Regulations for Alternative Onsite Sewage Systems*. If you have any questions, please contact your Service Operator.

- Keep a log for the TL-2 systems
 - Results of all testing and sampling
 - Reportable incidents
 - Maintenance, corrective actions, and repair of system components
 - Sludge or solids removal
 - Date and time reports were made and delivered to the system owner
- Collect a grab sample for the owner at the 180 day mark, and every 5 years after that date
- Notify the Local Health Department if the relationship with the owner ends

Material List

Below is a list of materials that are not supplied by Eljen, and are required to complete the Sampling Port.

- Sampling tube (size per design)
- Plastic or Concrete Lid for Sampling Tube
- 2" Schedule 40 PVC pipe
- Pea Gravel

Product Information

Collection Pan

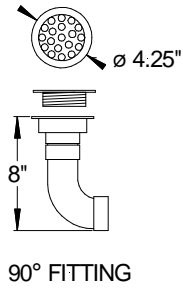
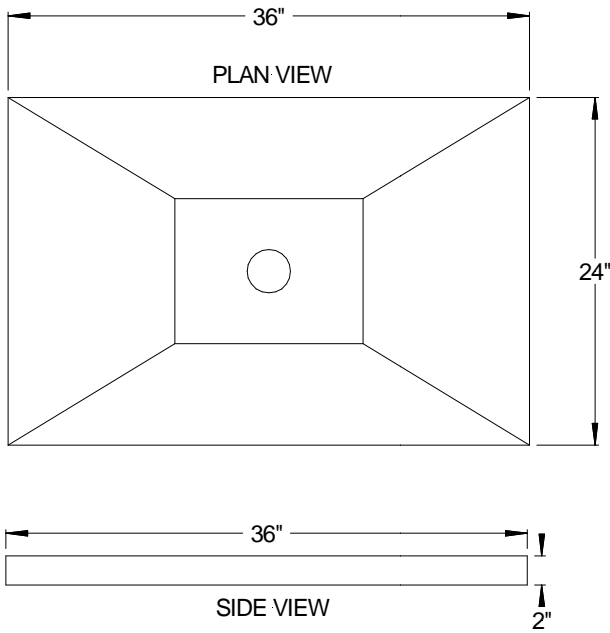

Sampling Tee Control Valve

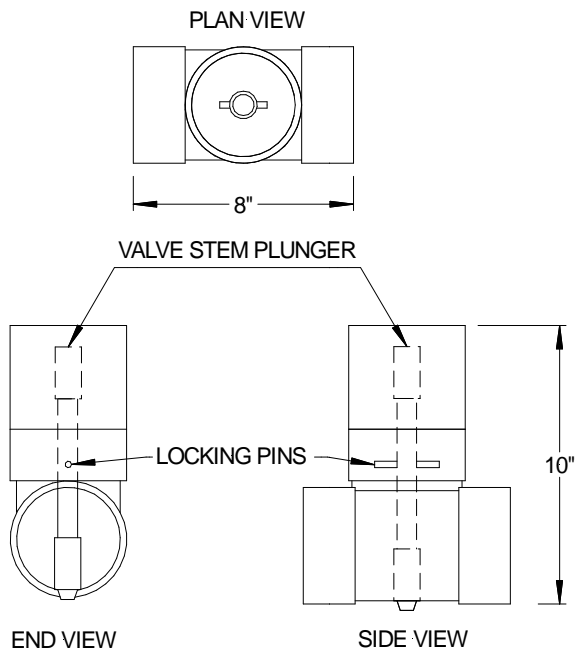

Observation and Sampling Port Installation

Observation and Sampling Port Preparation and Installation:

1. Determine the collection pan and observation and sampling port placement in the system. We recommend centered under one of the first two modules of an outside row.
2. Carefully lay out the system area and boundaries.
3. Prepare the site. Excavate a trench to the design elevation for the system.
4. Once finished, excavate the collection line trench perpendicular to the row and centered under one of the first two modules of an outside row. The trench should be wide enough to work in.
5. Excavate out an area next to this trench, this will house the observation and sampling port. The pit should be deep enough to provide a minimum pitch for the collection pipe of 1/8 per foot and be able to hold a minimum of 6" of washed pea gravel.
6. Within the trench, dig out a 36" L x 24" W x 2" Deep rectangle. This will house the collection pan. In the center of that rectangle, dig out an 8-inch deep rectangle or hole. This will house the 90 degree fitting used for the collection pipe. See drawing below.

Figure 1: Plan View

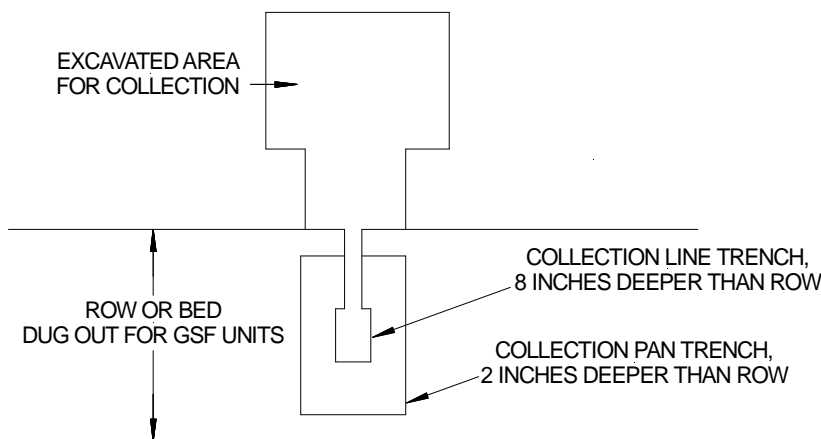

7. Place a minimum of 2" of washed pea gravel in the bottom of the sampling pit, and then place the observation and sampling port in the pit. Measure and mark the appropriate elevation for the collection pipe to enter the observation and sampling tube. Remove from hole and prepare to cut. *Note: Observation & Sampling Port may be constructed of any material as long as it allows for easy access to collection pipe. For this example we are using a 12" diameter plastic pipe.*

Figure 2: Plan View

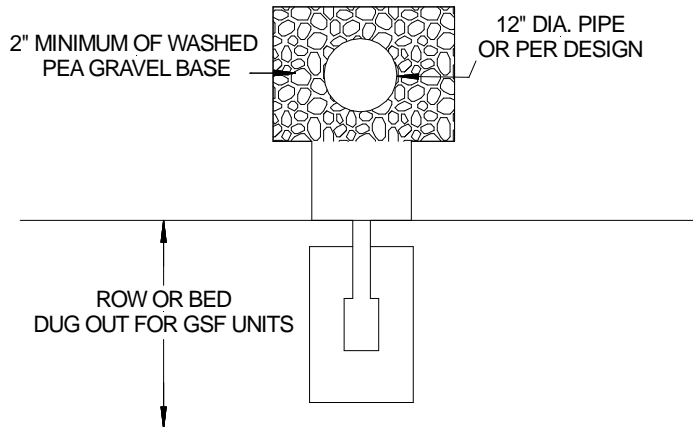

8. Within the trench, dig out a 36" L x 24" W x 2" Deep rectangle. This will house the collection pan. In the center of that rectangle, dig out an 8-inch deep rectangle or hole. This will house the 90 Drill a 2 3/8-inch hole (corresponding to the OD for the 2" collection pipe) in the observation and sampling port at the measured and marked location, equal to the prescribed 1/8 inch per foot pitch required.

Figure 3: Side View

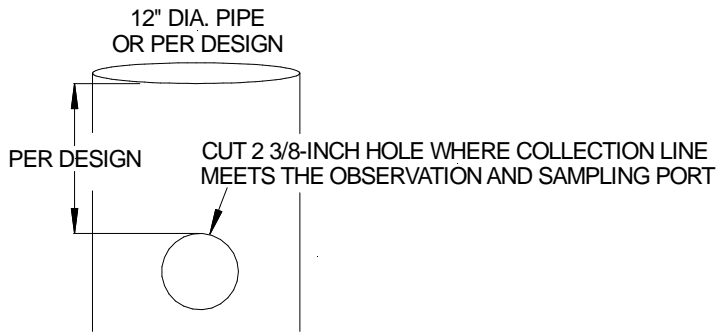

9. Place observation and sampling port back in the excavated hole and backfill the exterior of the observation and sampling port with washed pea gravel. Fill to the bottom of the newly cut collection line hole. This will help secure the observation and sampling port in place.

Collection Pan Installation:

1. Connect and glue the 90° fitting to the appropriate length 2" Schedule 40 PVC pipe. Insert 2" pipe into the observation and sampling port and center the 90° fitting in the pre dug collection pan trench. *Note: Recommended pitch on collection pipe is 1/8 inch per foot.*
2. Once the collection pipe is set, seal the collection line in the observation & sampling port.
3. Backfill around the pipe to secure in place.

Figure 4a: Cross-Section

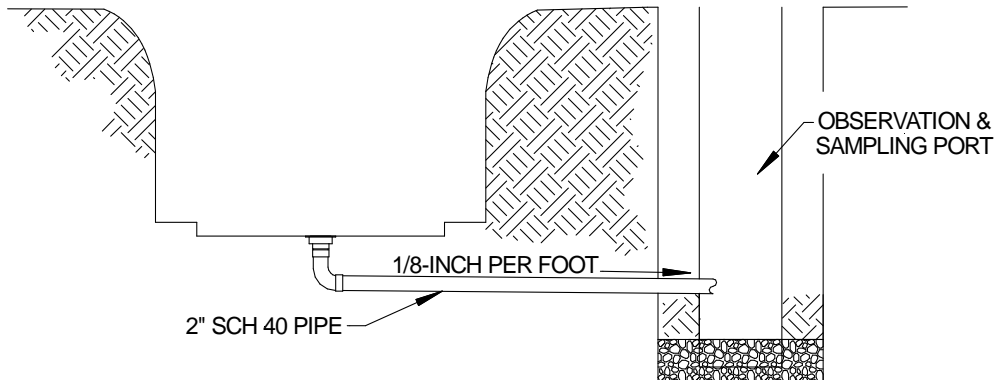
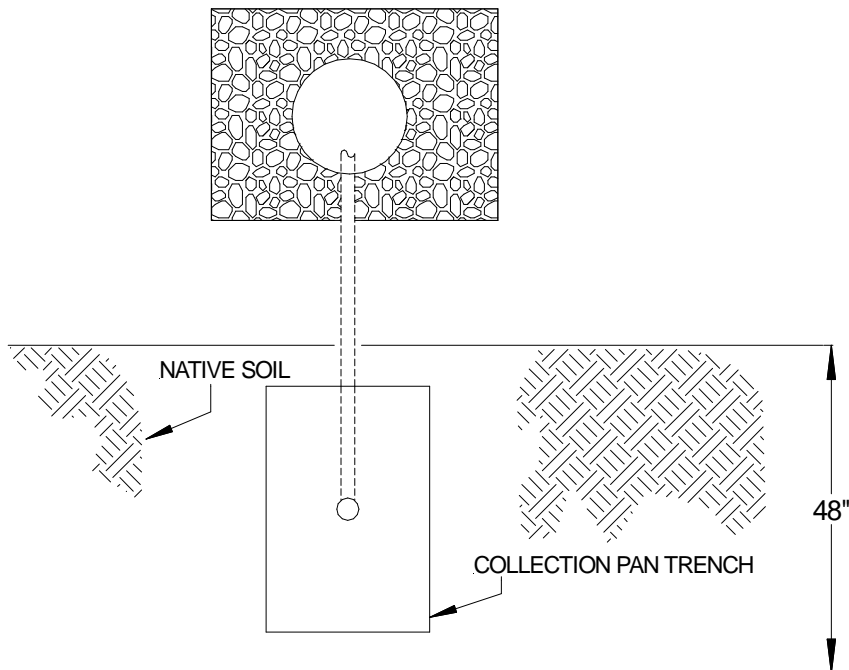

Figure 4b: Plan View



4. Place pan in the pre-dug collection pan trench with the pre-drilled hole over the 90° fitting. *Note: Pan must be installed a minimum of 12 inches below the bottom of the Eljen GSF Module.*

Figure 5a: Cross-Section

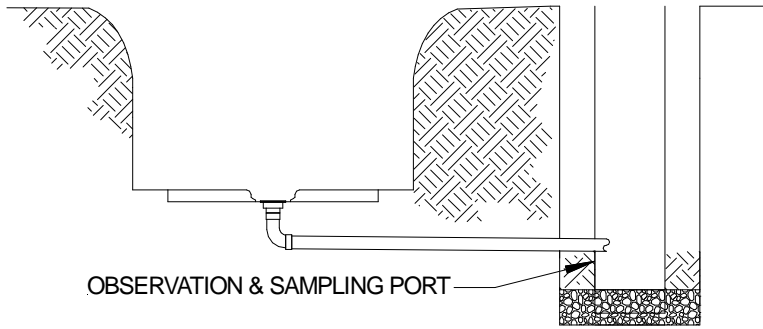
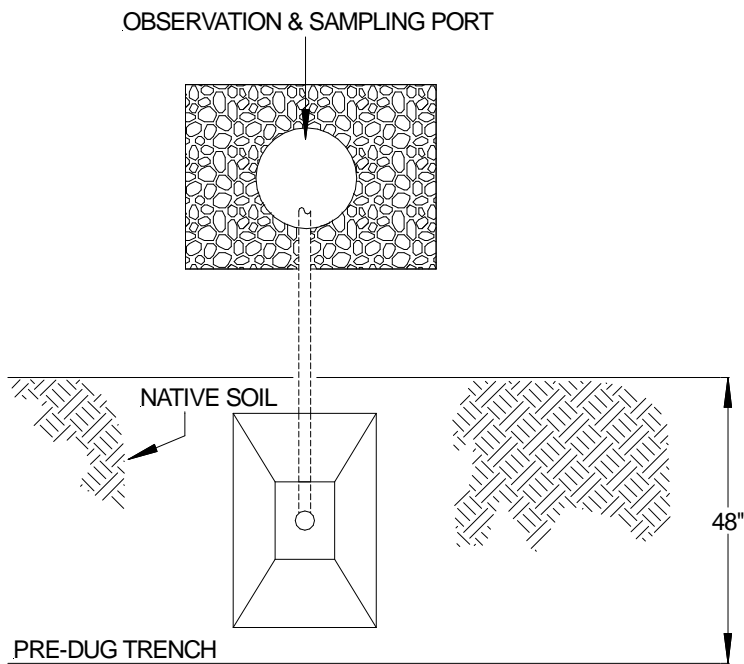
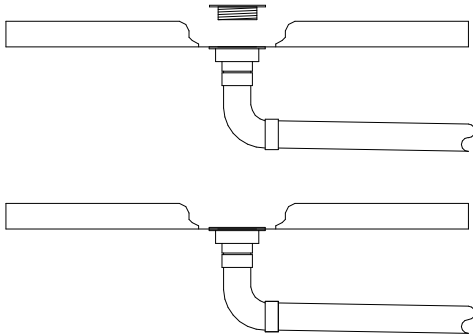

Figure 5b: Plan View



5. Connect the pan to the collection pipe by screwing the threaded screen adapter into the 90° fitting .

Figure 6: Side View



6. Fill the collection pan with washed pea gravel.

Figure 7: Cross-Section

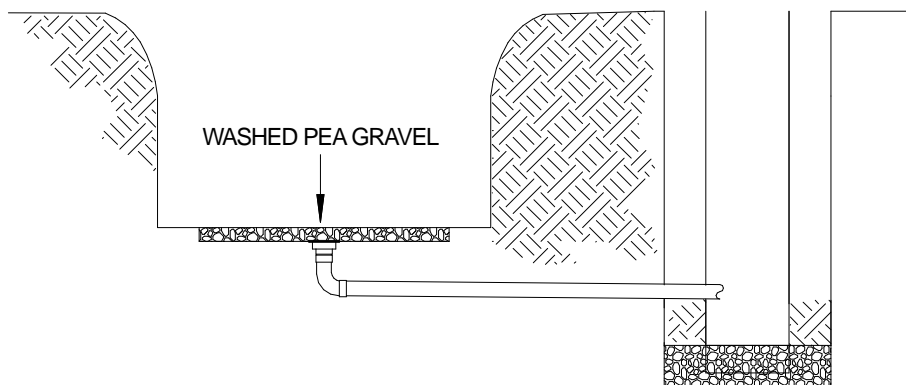

7. In the excavated trench, place Specified Sand in two 6-inch lifts, compact each lift at a time. The compacted Specified Sand height below the GSF module must be a minimum of 12 inches. *Note: No filter fabric is needed above the washed pea gravel.*
8. A hand tamper or vibratory compactor is sufficient to stabilize the Specified Sand below the GSF modules. Check the zero grade of the top of the Specified Sand using a flat piece of lumber and a carpenter's level and/or a laser before placing the modules.

Figure 8: Cross-Section

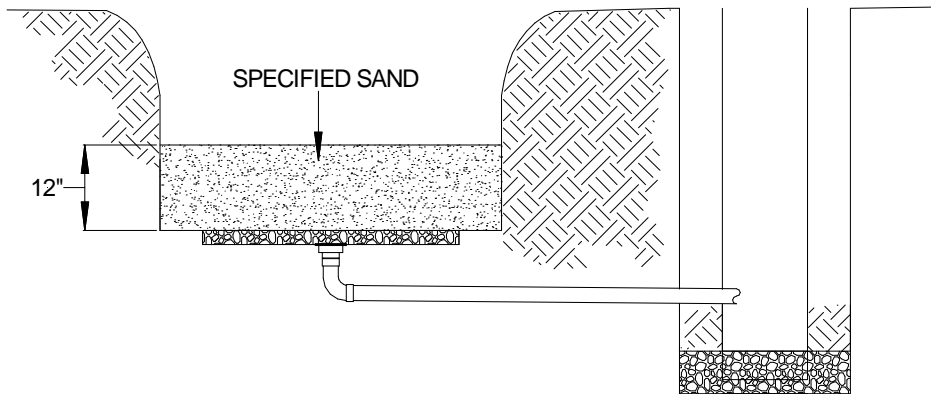

B43 GSF Module Installation:

1. Place GSF modules with *PAINTED STRIPE FACING UP*, end to end on top of the Specified Sand.
2. Provide D-box(s) installed in accordance with this manual and current *Virginia Sewage Handling and Disposal Regulations*.
3. Use 4-inch SDR-35 or equivalent non-perforated pipe from the distribution box to the GFS modules. Recommended drop for gravity systems from D-Box to modules is 1/8 inch per linear foot.
4. Center 4-inch SDR-35 or equivalent perforated distribution pipe lengthwise over modules with orifices at 5 and 7 o'clock positions.

Figure 9: Cross-Section

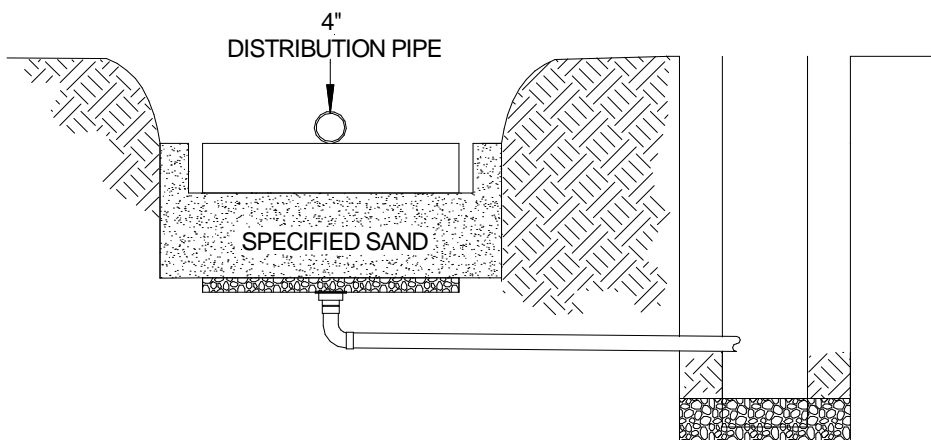

Sampling Tee Control Valve Installation:

1. Cut a 4-inch section out of the 4-inch SDR-35 or equivalent distribution pipe over the collection pan. Install the Eljen supplied Sampling Tee Control Valve (STCV) fitting making sure the pre-drilled hole in the STCV fitting is located above one of the open cuspatations channels in the module. This STCV fitting will allow the module, with the collection pan installed, to receive an adequate amount of effluent for sampling purposes. Reconnect piping and bond with appropriate solvent weld glue.

Figure 10: Cross-Section and Plan View

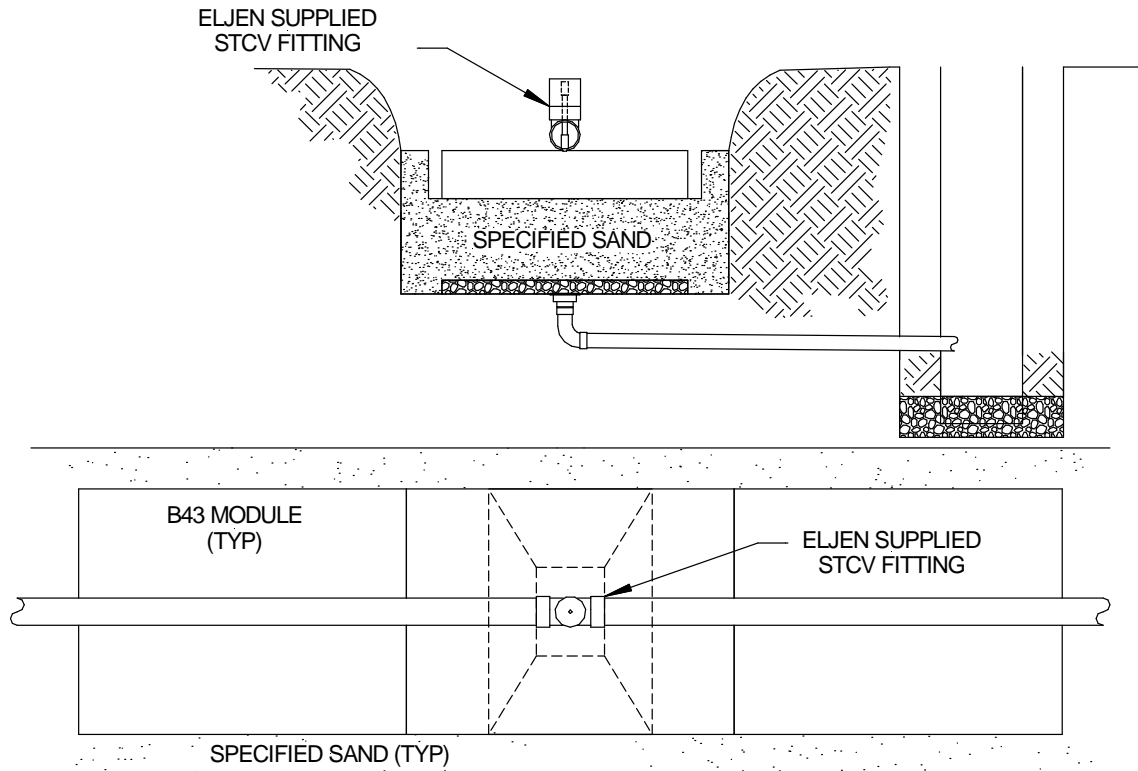

2. Add an appropriate length 4-inch PVC pipe section to the Eljen STCV and bring to grade. Cap pipe with provided 4-inch end cap to prevent soil intrusion during backfilling. Also, cover observation and sampling port with the appropriate sized plastic or concrete lid.

Figure 11: Cross-Section

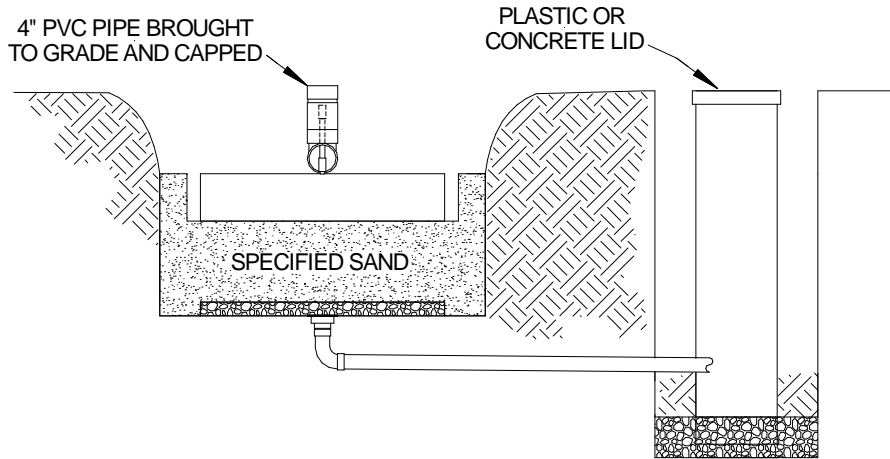

Final Installation Procedures:

1. Secure distribution pipe to GSF modules using one Eljen wire clamp per module. Push wire clamp ends straight down into up-facing core, through the fabric and into the underlying Specified Sand.
2. Spread the cover fabric over the top of the module and down both sides of the module with the cover fabric tented over the top of the perforated distribution pipe. **For the portion over the STCV, cut a slit in the direction of the pipe. It should now easily slip in place.**
3. Place shovel full's of Specified Sand directly over the pipe area allowing the cover fabric to form a mostly vertical orientation along the sides of the pipe. Repeat this step moving down the pipe. Anchor the cover fabric by placing Specified Sand along the sides and up to the top of the module and walk it in to ensure the cover fabric is secure in place.
4. Place 6 inches, 12 inches or 18 inches of Specified Sand along both sides of the modules and 6 inches at the beginning and end of each Modified Trench. See Table 2 or 3 in the most current version of the *Eljen Virginia Design and Installation Manual* for the amount of Specified Sand required at the sides of modules for your specific design and application rate.
5. Carefully place backfill over the modules, followed by loam to complete a total minimum depth of 12 - 18 inches as measured from the top of the module. Systems with total cover that exceeds 18 inches as measured from the top of the module shall be vented at the distal end of the system. Backfill material shall be a well graded sandy fill; clean, porous, and devoid of rocks. **Backfill around the inspection port and around the observation and sampling port.**
6. Divert surface runoff and finish grade to prevent surface ponding. Seed, loam, and protect from erosion.

Figure 12: Cross-Section

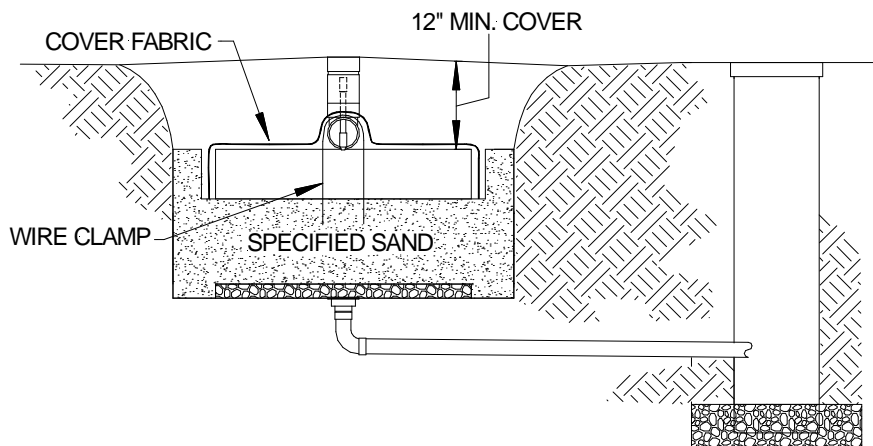

Sampling Procedures:

1. One week prior to sampling, inspect the system and observation and sampling port. If effluent is flowing out of the collection pipe a sample can be taken and submitted for testing at an EPA certified testing laboratory.
2. If effluent is not flowing; you must open the Sampling Tee Control Valve, pull up on the Valve Stem Plunger, and lock into place. This will allow the effluent to flow directly into the module above the collection pan and provide enough effluent for sampling. The Valve Stem Plunger must be left in the open position for at least one (1) week to provide enough effluent for sampling.

Figure 13: Side View

To Open:

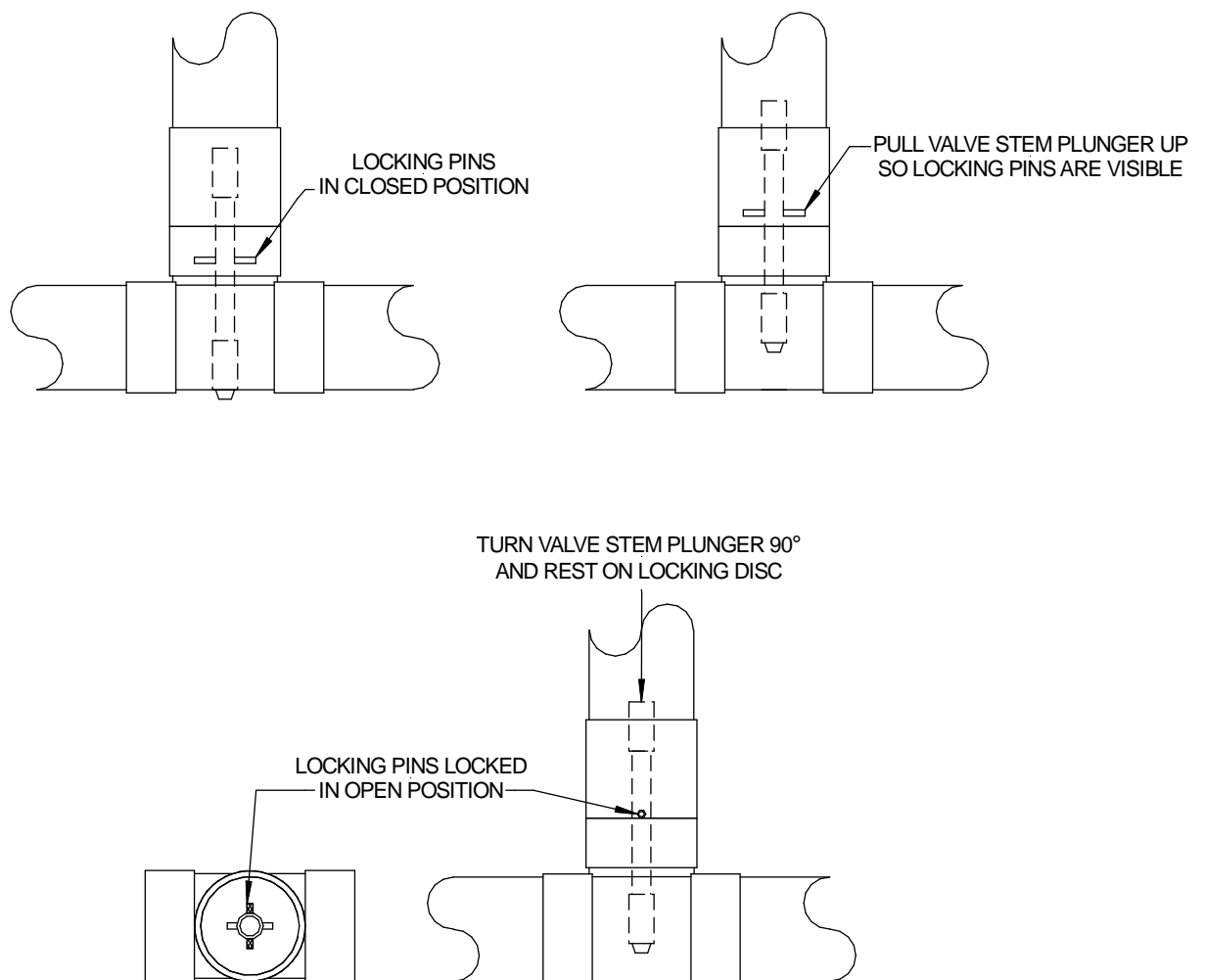

3. Once a sample has been taken return the Valve Stem Plunger to the closed position and replace the pipe cap. Submit sample to an EPA certified testing laboratory.